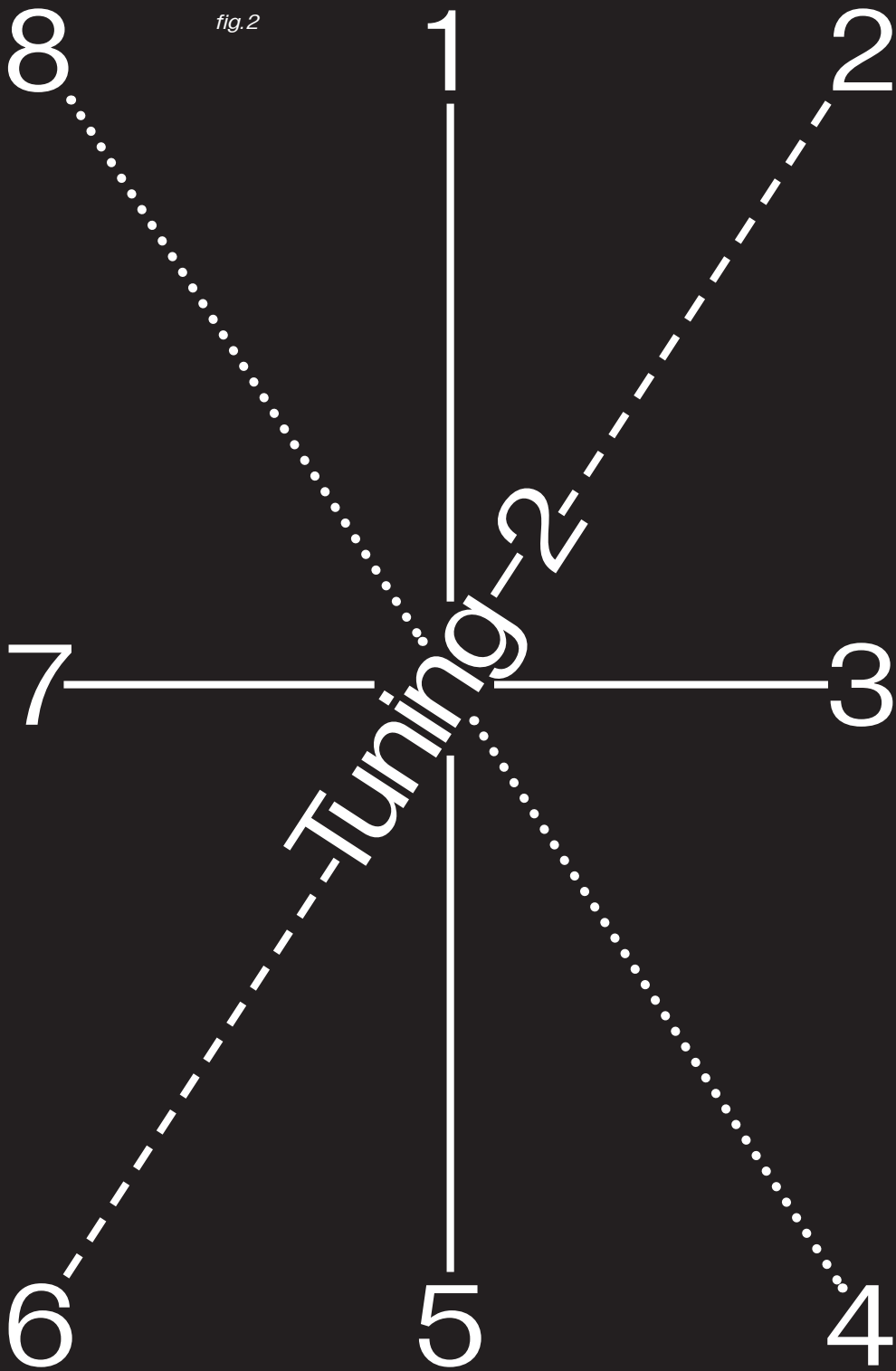

fig.2



!

Visitors sensitive to loud noises can borrow noise-cancelling headphones and earplugs at the Information desk

1

Tuning-2

Introduction

Tuning-2 is the continuation of the *Tuning* project that took place at GES-2 House of Culture from April to July 2022. *Tuning-2* brings together nine especially commissioned sound installations, a concert programme, and an exhibition that traces the connections which have run between music and formal experiments in the visual arts from the beginning of the last century to the present day. The exhibition seeks to showcase the various expressive techniques through which artists have created works that function not just on a visual, but on an auditory, even tactile level.

The first part of *Tuning* consisted exclusively of sound installations and proposed non-standard ways of reading music alongside the architecture of GES-2: music, an art form that works with and within time, was transformed and acquired new properties. Out of sound intended for an empty building, an event was born in which music imparted an additional dimension to space, while space imparted a stability to music. The resulting continuous, reciprocal exchange might be likened to the fluid, ongoing process of tuning itself, of searching for unusual conceptual combinations.

Tuning-2 draws on and develops the project that preceded it. This new chapter is both an extension of *Tuning*'s original concept and an attempt to trace subtler, more branched connections between the visual and the auditory. In *Tuning-2*, the sound installations of the original *Tuning* exhibition are joined by three new compositions—each written especially for GES-2 by contemporary Russian composers—and are complemented by works of fine art from the twentieth and

twenty-first centuries which explore the representation of space through its construction, distortion, and decay.

Over the course of the twentieth century, artists moved further and further away from the long-established tradition of mimetic representation of the real world. Reflection on the nature of art and its modes of existence led artists to bold experiments with form. On abstract canvases, the pictorial space organised itself around the interplay of simple geometric shapes, of compositions of lines and coloured spots—their rhythmic repetitions and harmonies brought fine art closer to music than it ever had been before. Non-objectivity gave rise to even bolder experiments, and to syntheses of different types of art—of painting and sculpture, for example. Other artists went so far as to attempt to render their works practically invisible.

Tuning-2's exhibition comprises four chapters. Its first chapter outlines the history of pictorial abstraction, beginning with works of the European and Russian avant-garde and ending with works by contemporary artists. Its second chapter is dedicated to the metamorphoses of sculpture: to its gradual rejection of figurativeness or, alternatively, its increasingly narrative bent, as well as to the emergence of transitional forms between sculpture and painting. In the exhibition's third chapter, visuals fade into the background, are at times even emphatically denied as artists dissolve their works in the exhibition space. *Tuning-2*'s fourth and final chapter explores two of the most important sociocultural functions of music: its role as a source of inspiration for and influence on the organisation of collective experience.

1 Non-objectivity as a new visual language

Level -1, Gallery C4

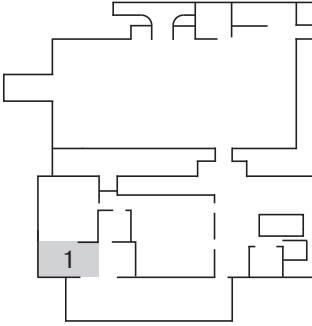

The first chapter of this exhibition is dedicated to abstract art and its close relation to the methods for constructing musical works that were developed in the twentieth century. Geometric forms, rhythms, and harmonies constructed new spaces and altered existing ones, and in doing so brought painting close to music.

The beginning of the twentieth century saw a breakthrough take place in art: struggling with the canons, artists turned away from realistic representations of the world around them, even from the linear perspective consistent with human perception that had been developed during the Proto-Renaissance (from the thirteenth to fourteenth century). Whether they represented scenes from visible reality or imagined idealised worlds, up until this point artists had founded their works on familiar objects and landscapes. Now, the creativity of a fundamentally new visual language prevailed: the artist constructed reality from nothing, populated it with unprecedented objects, and invented unusual scenarios for them.

This chapter of the exhibition begins with the historical avant-garde—David Burliuk (1882–1967), Wassily Kandinsky (1866–1944), Alexandra Exter (1882–1949). It continues on through the European experiments of the twentieth century—Bridget Riley (b. 1931), Gerhard Richter (b. 1932), Victor Vasarely (1906–1997), Sigmar Polke (1941–2010), Rosemary Trockel (b. 1952), Günter Förg (1952–2013), and Hans Hartung (1904–1989), before ending with contemporary readings of non-objectivity by Liz Deschenes (b. 1966) and Wade Guyton (b. 1966).

If Alexandra Exter's early Cubist canvases represented a fragmented, faceted reality, her later works arrived at the triumph of pure geometric form, as in *Construction of Planes According to the Movement of Colour* (1918). This profound, creative experiment would ultimately result in the creation of new, previously non-existent forms in painting.

Wassily Kandinsky was one of the main pioneers and theorists of non-objective art. His artistic methods influenced the senses and the imagination, and were

in many ways similar to music. In his 1910 treatise *Concerning the Spiritual in Art*, Kandinsky's comparison of the laws of composition and colour harmony with musical notation saw colour and harmony take the place of notes. "Colour is the keyboard," he wrote, "the eye is the hammer, while the soul is a piano of many strings. The artist is the hand through which the medium of different keys causes the human soul to vibrate." A painting thus becomes the creation of a world. Kandinsky's later painting, *Krass und Mild* (1932) is a triumph of pure abstract form, a confirmation of the principle dear to the artist according to which harmony in painting and music are of the same nature.

By the middle of the twentieth century, abstract art was approaching conventionality, with nothing left to prove or subvert. Once again, the time had come to redefine the essence and task of pictorial abstraction.

In his works, Victor Vasarely made use of the laws of optics to create illusions on canvas that convinced their viewers of their three dimensionality, notably in *8-4* (1973–1975). Drawing on Vasarely's work, Bridget Riley attains an illusion of an entirely different nature in *Stretch* (1964). If the work of art had previously drawn the viewer into its orbit but itself remained unchanged, in Riley's practice works are brought to life and altered when they come under the viewer's gaze. The spectator becomes the artist's co-author—it is in this way, Riley explains, that she shares her "particular joy," giving to each the ability "to feel themselves alive."

The musical experiments of the twentieth century require a similar engagement from the public—so-called active listening. If not a co-author, the listener proves an important participant in the process, not least because this new music—and that of John Cage and other American minimalists in particular—is literally created anew each time it is performed.

In his abstract work, *Wer hat noch nicht, wer will nochmal* (1984), Sigmar Polke takes the halftone pattern—the small dots used to reproduce images on newspaper pages—to its limits. Halftone and pixelated graphics are frequently used techniques in art that critically reflects on problems of reality and its perception in a world ruled by mass media and that questions the role of communications technologies—of media and messengers, for example—as agents of social change.

If newspaper printing occupied an important place in Sigmar Polke's painting, photography occupies a correspondingly important one in Gerhard Richter's

work. Contrary to the established conventions of non-objective art, his *Abstraction 721-3* (1990) rejects the idea of the artistic canvas as a sacred space. Applied to the canvas in a surgically attentive imitation of chaos, layers of paint successively cancel one another out, and in doing so bury modernist abstract painting as behind them a photographic image emerges. Though he makes use of the techniques of oil painting, Richter all the while underlines the fact that today's world is impossible to convey through classical artistic means, even when these are passed through the prism of the avant-garde.

In their experiments, contemporary artists free themselves from painting itself, albeit whilst continuing to pay tribute to it and partly mimicking it. Liz Deschenes's *Bracket 3*, part of her 2013 series, is one such work: this gelatin silver print on aluminium recalls the canvas of a painting. A dark reflective surface with a metallic lustre hangs in the air, forming something intermediary between sculpture and photography. The painting borrows its name from bracketing, a method in photography whereby a series of images of the same subject are taken with a single variable changed—shutter speed, aperture, or focus.

Wade Guyton runs primed canvases through large-format printers which leave behind chaotically scattered marks that form into accidental variations and patterns. Post-painterly abstraction engenders itself here with the help of office technologies and without a single brushstroke. The painting no longer requires direct contact with its author, who becomes more akin to a conductor or operator in this new means of creation.

Over the course of the twentieth century, experiments with pure form and technology freed art from the need to imitate reality, even to bear any relation to it. Artists searched for consonances in musical experiments as they defined the role of the artist anew: where he had once been a creator and producer, he now became a researcher.

2 Three-dimensional experiments

Level -1, Gallery C4

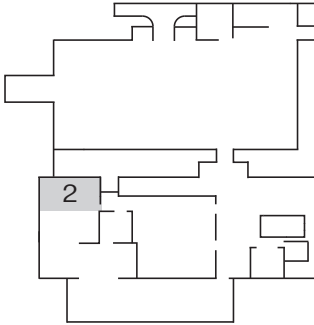

The subject of this chapter is the path taken by European sculpture over the last hundred years, the milestones of which are the works of the most important masters of the twentieth century. During this period sculpture, like painting, becomes a space for radical experimentation, with artists turning away from realistic representation and thereby from the elevation of human perception to the level of an indisputable law. Turning to abstract forms, here too artists devised a new visual language, constructing complex metaphors and beginning to use materials unusual for sculpture. Previously incompatible traditions, cultures, and contexts met and intertwined.

Dramaturgically, this chapter might be likened to a three-part dialogue. On one side, we have the works of Alberto Giacometti (1901–1966), Henry Moore (1898–1986), Constantin Brâncuși (1876–1957), Willem de Kooning (1904–1977), and Louise Bourgeois (1911–2010)—well known works, which allow us to trace the evolution of sculpture from the figurative to the abstract. On another, we have the narrative, proactively subject-based sculptural compositions of Paweł Althamer (b. 1967). These two lines meet in the work of Giuseppe Penone (b. 1947), where the transition from the pictorial canvas to sculpture is accomplished literally, clearly, and almost tangibly through the introduction of three-dimensional objects to the plane.

Sculpture in the round (that is, three-dimensional sculpture) had previously been interested primarily the human body, preferably idealised and harmonious. It now became the domain of formal exploration. A striking example of this is Constantin Brâncuși's *Le premier cri* (1917). This bronze, egg-shaped object—with a single hollow symbolising an open, crying mouth—reads as a striking and complete image of new life.

As was the case with many other modernist artists, Brâncuși's work was deeply influenced by art from the African and Oceanian countries that had been colonised by European powers. The spontaneity, freedom from rules, and vitality of these simplified

forms was in opposition to the strict canon of European tradition—a new artistic language was taking form.

Traces of a familiarity with this new artistic language can be found in the works of Louise Bourgeois (1911–2010). *Untitled (The Wedges)* (1950) is practically a pagan totem. A primordial mysticism makes itself felt here, in contrast to the rationalism of European civilisation. In Henry Moore's *Working Model for "Reclining Woman: Elbow"* (1981), we also find references to archaic female figures and symbols of fertility.

In the work of Alberto Giacometti (1901–1966), human bodies are often so elongated they become almost string-like, as though at the utmost point of exhaustion. His *Femme debout* (1957) is not simply an experiment in figurativeness, but an emotional statement. This slightly bowed figure speaks to the fact that for all its fragility and defencelessness, mankind was able to withstand the severe trials of the twentieth century, its world wars and industrial disasters, and accompanying, loud-voiced declarations of humanitarian values.

An utterly particular approach to the search for a new sculptural language is apparent in Willem de Kooning's *Large Torso* (1974). One of the most renowned of the abstract expressionists, de Kooning's works capture the birth of the human figure as it emerges from formless material—an energetic gesture, reminiscent of the creation of the world from primordial chaos.

At least at first glance, Paveł Althamer's *Ognisko (Camp Fire)* (2012) can seem to continue this formal tradition. Four figures of epoxy resin are settled around an absent camp fire. Each of them is either melted or mutilated. To some viewers, they are representations of ancient souls, to others, they are beggars warming themselves around the scrap-heap after a hard day. Or perhaps these aren't living people after all, but rather the remnants of a planetary catastrophe.

The work of the Italian artist Giuseppe Penone is a transitional form between sculpture and painting—in his *Spine d'acacia—palmo* (2004), a palm-print made of thousands of acacia thorns covers a silk canvas. This fragment is a part of the larger *Anatomy* series, which Penone has described as “a game with three elements: animal, vegetable, and mineral.” The work makes manifest one of Penone's key themes, the affirmation of harmony between mankind and the universe. This harmony is underscored by Penone, who brings in nature herself as co-author, notably in *Spazio di luce* (2008), a work which can be seen at the foot of GES-2's birch Forest.

3 On the threshold of the visible

Level -1, Gallery C4

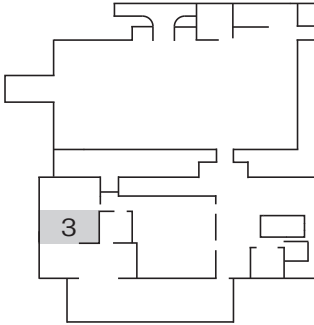

This chapter comprises works which quite literally vanish into thin air. Space here functions not just as a neutral backdrop but as a full-fledged actor, as capable of illuminating an object as it is of muffling it or carrying it away into the shadows. Whether they mimic their environment or merge with it, these works require the active participation of the viewer, demand an effort in order to be perceived. The works of Florian Pumhösl (b. 1971), Alighiero Boetti (1940–1994), Liz Deschenes (b. 1966), Daniel Knorr (b. 1968), Sarah Charlesworth (1947–2013), and Isa Genzken (b. 1948) have been brought together in a total installation that invites viewers to attune to subtle differences in their forms and features and to consider how their field of vision is marked and organised—what is included in it, what is excluded. Is visibility an inherent property of things, or a quality imparted to them by the viewer?

The logic of the development of modernism exposed the conventionality and insignificance of pictorial norms, and led gradually to the laying bare of the painting itself—reduced first to a monochrome surface, then to the state of a simple stretched canvas. With time, the impulse to eradicate any traces of objectivity or imitation of reality only increased. Importance was increasingly attributed to the various ways in which art might be “framed”—formally, linguistically, sociologically, institutionally—everything, in other words, that lies outside the frame yet makes artistic experience possible. Invisibility, absence, emptiness—these are points of departure, zones of uncertainty and indeterminacy, of an open and endless generation of meanings. Invisibility, of course, can signal intentional concealment, but by the same token it can signify a gaping absence, draw attention to what is repressed or silenced, to what can be perceived only peripherally, to what exists only as an unsteady afterimage or eludes our attention. Invisibility inspires confusion, upsets and reconfigures our habitual, normative conditions of perception. Finally, invisibility creates situations in which the observed object returns the gaze we direct at it and begins to look at us.

It is precisely their own reflection that viewers of Liz Deschenes's *Shift/Rise #32* (2011) are confronted with. Moving about the hall, catching, from various perspectives, their reflection and that of the objects surrounding them in the flatness of the mirror, viewers materialise the very act of seeing and at the same time awaken ghostly images of the work—a photograph, taken without the participation of a camera.

Florian Pumhösl's series of deceptively simple plaster reliefs (2016–2017) was created for the reconstruction of El Lissitzky's *Room for constructive art*, designed in 1926 for the abstractionists' show at the Dresden International Art Exhibition. Almost a hundred years later, this interior was reconstructed according to a single remaining photograph. Pumhösl set himself the task of thinking up what might fill such a hall today. Though at first glance, his reliefs might seem almost primitive, each of their lines refers to the historical context of a century ago. The four plaster compositions along with the intentionally omitted one (the reliefs are numbered I–V) serve as points of intersection for the formal and historic, for the abstract and the maximally concrete. The work of art, Pumhösl insists, cannot be closed in on itself or on its artistic means, whatever the declarations of the modernists may be.

Sarah Charlesworth takes up the theme of the imaginary and the visible in her series *0+1* (2000). Though they appear at first as black and white sketches, these works are in fact full-colour photographs. In as far as all the objects in the series are shot against a white background flooded with bright light, the boundary between figure and background is almost imperceptible. The threshold of visibility thus becomes the centre of attention, though Charlesworth is also interested in the threshold of entry into world visual culture. It is precisely for this reason that the subjects and images selected are entirely commonplace—the Madonna and Child, the skull (a symbol of the transience of earthly life in Dutch still-lives of the seventeenth century), the pagan goddess, the seated model, the grid as organizing principle of modernist art.

Alberto Boetti's *Lampada annuale* (1967) is a lacquered black box with a glass lid, its insides covered with metal, and a huge bulb fixed in the middle. Minimalistic in form, the object seems a part of some perplexing scientific device, the leftover of a mysterious experiment. Hidden deep within the box is a clock mechanism. Once a year, this mechanism selects a moment at random during which the bulb will flash for eleven seconds. It only takes viewers knowing that this

object might unexpectedly awaken in their presence (even if the likelihood of it is negligible) for the deceptive simplicity of the device to take on a peculiar, almost magical aura, and for an event invisible to the majority of visitors to provide an impetus to new interpretations.

Daniel Knorr's *Capillaire* (2015) is formed of several acrylic tubes containing samples of a wide variety of poisons: brugmansia (a poisonous tropical shrub, a type of *Datura*), belladonna, arsenic, spotted hemlock, etc. If we see the building as an organism, and the exhibition space as one of its organs, then these tubes become analogous to blood vessels. The poisons that have found their way here are of an ambivalent, flickering nature. In Ancient Greece, the term "pharmakon" could denote medicines and potions as much as it could poisons. An analogy more pertinent to our times might be antibodies, which are at once signals of possible disease and necessary to its cure. Just as throughout history, poisons have served as both means of miraculous escape and of doing away with opponents, so Knorr sees in them at once a means of biopolitical control over the body and a way of evading it.

From the late 1970s to the early 1980s, Isa Genzken created oblong, curved wooden sculptures—ellipsoids and hyperbolas constructed according to complex computer calculations. In doing so, Genzken did not simply, to borrow Alexander Pushkin's phrase, verify the harmony of the universe through algebra, but straightforwardly polemicised with the tradition of minimalism: choosing a deliberately whimsical form, Genzken invited her viewer into a game of visual association by including this premeditated, invisible emotional layer in her work. As Genzken herself commented: "I would like people to talk about ellipsoids — 'It looks like a spear—or a toothpick—or a kayak'—I laid the foundation for this associative moment from the very beginning." The aerodynamic form of her objects can make them seem industrially produced, though in fact they are all handmade. This exhibition displays a life-size blueprint for one of Genzken's ellipsoids, made around 1976 with the help of a computer programme that visualised accurate, mathematically verified calculations and allowed for their transformation into sculpture.

4 Practicing the collective gesture

Level -1, Gallery C4

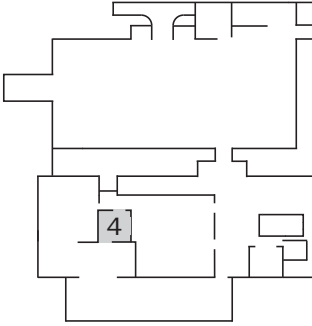

The three previous chapters explored the ways in which artists have experimented with form throughout the previous century—how they moved away from realistic representation, broadened the expressive possibilities of abstraction, and called the principles of musical harmony, rhythm, and metre to their aid.

This concluding chapter brings together *Rite of Spring* (2012) by Enrico David (b. 1966) and *Ode* (2001) by Victor Alimpiev (b. 1973). It holds a special place in the *Tuning-2* project, as the dialogue between these two works materialises the central theme of the exhibition—the attunement of sound and image. Both works underline the important role played by music in experiences of belonging, collectivity, and rituality.

David's *Rite of Spring* refers to the fertility rite that takes place before the start of sowing, a rite which has existed in one form or another in all ancient agricultural cultures. The most well-known artistic interpretation of this rite is the ballet *The Rite of Spring* (1913)—revolutionary for its time, the work was staged by Vaslav Nijinsky to music by Igor Stravinsky during one of the Diaghilev Seasons in Paris. The performance's scenery, costumes, and libretto were the work of the artist and mystic Nicholas Roerich. Nijinsky's bold choreography—founded on the repetition of intermittent, ecstatic gestures which transform the performers into a single organism—conveyed the spirit of this pagan ritual extremely accurately. On David's canvas, sketchy female figures form a harmonious, rhythmic row, recalling an archaic ornament. The figures create an illusion of monotonous movement, and are a capacious metaphor for the continuous flow of life.

David's harmonious pictorial sequence is contrasted with a film in which a group of people also seem to be performing some kind of ritual. This impression, however, is deceiving. Here the choreography of the collective body is determined not by rules but by the chaotic screen narrative: Alimpiev's cinematic language is an explosive mixture of music, absurd plasticity of characters, and unnatural image imitating a damaged videotape.

The dramaturgy of the mise-en-scene is clearly dictated not by the scenario but by the reactions of the characters to the audio sequence and to the actions of their partners. The participants in this absurd performance cry out certain phrases at random, but there is no harmony to this chorus; there is nothing before us but a mechanic sum of actions, colours, and sound effects. Interspersed human speech makes the acoustic fabric of the work all the more colourful.

5 Mark Buloshnikov Moments

Level 1, Prospekt
Level 2, Central platform

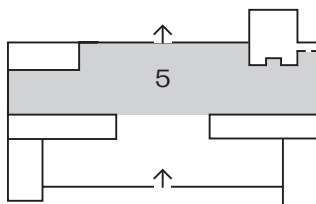

2022
Sound installation
360 min.
Sound engineer:
Andrey Titov-Vrublevsky

Ivan Bushuev's *I campi dei ricordi*
(see page 18)
plays here 17:00–22:00,
Monday to Sunday

At the centre of Mark Buloshnikov's concept lies an attempt to understand the genre of musical installation not as a static, looped, and repeating form, but as a dynamic one that develops in time and space.

Each of the successive six hours of *Moments* corresponds to a particular musical key. In parallel, the rhythm gradually speeds up, from a slow to a fractional pulse, while the instrumentation becomes more and more diverse.

Musical material is repeated only once in this over-large form—a slow foxtrot is heard at the very beginning and at the very end of the composition. Its melodic echoes are heard throughout the piece—changing duration and timbre coloration, fragments of this foxtrot lasting from 3 to 10 seconds appear and disappear against a background of long notes by string instruments separated by pauses. This “background” to the installation has a double meaning: it both resembles the process of tuning musical instruments and, metaphorically, suggests an attunement to something higher.

Precisely which elements of the pre-recorded material will sound out at any given moment is determined by a computer programme, making all the harmonic combinations of *Moments* unintentional, and allowing the piece's soundscape to endlessly renew itself.

Mark Buloshnikov

(Nizhny Novgorod, 1990)
is a composer. He is a graduate of the Glinka Nizhny Novgorod State Conservatory, where he studied composition under Boris Getselev and musicology under Tamara Leva. He went on to complete an assistant-traineeship with Boris Getselev. He is a laureate of the Step to the Left international composing competition. He is the NoName ensemble's artistic director and pianist, and the Chairman of the Nizhny Novgorod branch of the Union of Russian Composers.

“The space of location and time is inevitably filled with events — often fleeting and barely perceptible, but hinting at something more. It is as though we had awaited a downpour, but found only fine rain. The storm approached and passed us by, but all the same our memory picks up the signals and knows about the storm, just as a leaf stores information about the entire tree. In short, even the most modest of material has its own DNA and rich information.

Moments is a space of the possible where the understatement and fragmentation of the message along with the softness and care of presentation are references to the anticipation of our perception as listeners, reacting to musical signs. In this case we take signals as a kind of narrative. However, such forms can also be perceived as non-narrative, as a peculiar enumeration of musical moments.”

6 Ivan Bushuev

I campi dei ricordi (Fields of memories)

Level 1, Prospekt
Level 2, Central platform

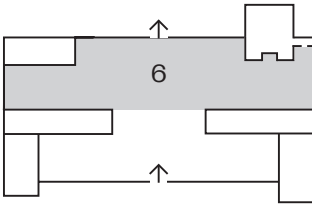

2022
Sound installation
Variable duration
Sound engineer:
Andrey Titov– Vroublevsky
Commissioned and produced
by V–A–C Foundation
Monday–Sunday, 16:00–22:00

Mark Buloshnikov's *Moments*
(see page 16)
plays here 10:00–17:00,
Monday to Sunday

Ivan Bushuev

(Moscow, 1984)
is a composer, conductor,
flautist, a soloist of the Moscow
Contemporary Music Ensemble, and
the author of the electronic music
project *nerest*. He is a graduate
of the Moscow State Tchaikovsky
Conservatory's historical and
contemporary performing arts
faculty. He has trained at the
Baroque Academy in Gmunden,
studied the transverse flute and
modern flute in Milan, and attended
the Jan Sweelinck Conservatory in
Amsterdam as an exchange student.
He is a laureate of a number of
international competitions.

The word *campo* (field, clearing) in the title of Ivan Bushuev's installation has a number of meanings. Along with a “field of thought,” that is, a sum of associations, the word is a reference to “field recordings”—recordings of the sounds of an environment. Finally, *campo* is the name given to open urban spaces in Venice, with each of the city's many islands having its own main meeting-place, or *campo*. Strictly speaking, the area in front of Saint Mark's Cathedral is the only *piazza* (square) in the city.

I campi dei ricordi includes field recordings of works by the Venetian composer Giovanni Gabrieli made during the final concert of the *Tuning* project's May 2022 programme. Gabrieli composed his *Canzoni* especially for Saint Mark's Cathedral, taking into account the basilica's structure—a cross with many galleries and niches—and the positioning of his musicians. The audience, sat on the ground floor of the cathedral, followed the movement of sound from gallery to gallery above. One of the devices Gabrieli most frequently turned to was the echo, in which a single musical phrase is repeated from a number of different points. For the concert at GES-2, the musicians of the Moscow Contemporary Music Ensemble were positioned throughout the House of Culture in a similar way to how Gabrieli's would have been in Saint Mark's.

Gabrieli's *Canzoni* sound out alongside recordings made on different days of the *Tuning* project—echoes of Vangelino Currentzis's *Resonance* installation, which previously occupied the Prospekt, can be made out, as can other noises made in this space. The entire composition might be thought of as an acoustic memory.

“In my work with electronic music, I have always been interested in juxtaposing spaces and memories, in attempting to convey the acoustics of a place that are heard only inwardly. Music lives in the consciousness and subconsciousness of an author constantly, where it is joined by the sounds of the city, mixed with memories of other music and events that occurred in various places. Memory undergoes constant transformations, generating something new which might never have existed in reality. Images are romanticized, and a new layer appears, a variation of the original memory.

Working on the installation, I thought of the different ways the *Canzoni* might have sounded to Gabrieli himself—in his own head, under Saint Mark’s vaulted ceiling, on noisy Venetian *campi*. How did the composer feel the difference between these acoustics? *I campi dei ricordi*

is composed of fragments which are at first glance entirely unrelated to one another, but united by a common theme—memory. The memory of light, sound, smells, and of those acoustics that have surrounded and surround us. I have imagined each field, each *campo*, as a separate space, with its own events, flashbacks, and landscapes.”

Ivan Bushuev

7 Vladimir Rannev Tuning

Level 2, Gallery C7

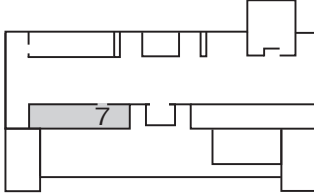

2020–2022
Sound installation
17 min.
Sound engineer:
Andrey Titov–Vrublevsky
Commissioned and produced
by V–A–C Foundation

Vladimir Rannev's *Tuning* is composed of 115 final notes taken from 115 musical works of the eighteenth and nineteenth centuries.

The work is founded on a paradox. We are taught to value musical compositions of the Romantic era, which stretches from Mozart to Mahler, for their inimitability and the uniqueness of their artistic ideas. Yet a common thread runs through all these compositions—their final notes. And although one would hardly argue final notes to lack signs of authorial will, fantasy, or inspiration, we nevertheless tend to expect one and the same thing from them: a major or minor chord in a limited number of dynamics, registers, and timbres. This is how mechanisms of collective memory function, endowing all of us with a symbolic language of perception, the ability to distinguish between sense and nonsense.

One way of understanding the history of music might be to regard it as a gradual tuning of the collective auditory experience. Relatedly, the history of humanity can be understood as a gradual attunement of people to one another as well as to that imperceptible thing which, as Egor Letov sang, “is not to be heard by ears, not to be understood by the mind.” In the words of Vladimir Rannev, “the final note is found on the border of the attainable, after which there is only silence.”

Vladimir Rannev
(Moscow, 1970)
is a composer. He graduated from the Rimsky-Korsakov Saint Petersburg State Conservatory and the Cologne University of Music. Rannev won the Sergey Kuryokhin Award in 2013 (for his 2012 opera, *Two Acts*), the Casta Diva Russian Opera Award in 2017, and a Golden Mask National

Theatre Award in 2019 (his 2017 opera *Prose* won him the award for Best Composer). In 2019, Rannev took part in the *DK Zattere* project with his sound installation, *Kitezh* (V–A–C Zattere, Venice). In collaboration with Marina Alekseeva, Rannev is the author the installations *In Chocolate* (2019), *Ready to Repeat* (2019), and *The Whole Shebang* (2020).

8 Eduard Artemyev GES-2. Anthology. Part I.

Level 2, Gallery C6

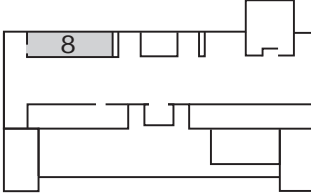

2020–2022

Sound installation

40 min.

Remastered for GES-2

by Damien Quintard with

Eduard and Artemiy Artemyev

Original recordings

courtesy of the artist

Commissioned

by V–A–C Foundation

Over the course of his long career, Eduard Artemyev has written a remarkable number of melodies across a vast range of genres. *Anthology*, which Artemyev put together for GES-2 in collaboration with V–A–C’s sound director, Damien Quintard, brings together pop–ballads and electronic soundscapes, experiments with the Soviet ANS synthesizer, and the scores of Andrei Tarkovsky’s *Solaris* (1972), *Mirror* (1975), and *Stalker* (1980). The pieces selected for *Tuning* are among Artemyev’s more rarely–performed, unremembered works, with many of them practically unknown to a wider audience.

The works in *Anthology* interact with the architecture of GES-2, transporting listeners to different worlds and faraway places. Re–recorded and re–mixed compositions from the animated film *A Girl and a Dolphin* (1979), from the war drama *Hot Summer in Kabul* (1983), and from other Soviet films that have almost fallen out of public memory will ring through GES-2 in a completely new way. Artemyev’s multi–channel installation positions listeners at the very centre of the music, where, not unlike composers, they find themselves explorers of new territories, on the threshold of great discoveries.

Eduard Artemyev

(Novosibirsk, 1937)

is a composer and the author of the scores to many classic films and cartoons. He was a pioneer of Soviet electronic and electro–acoustic music.

9

Vladimir Rannev Kitezh

Level -1, Gallery C2

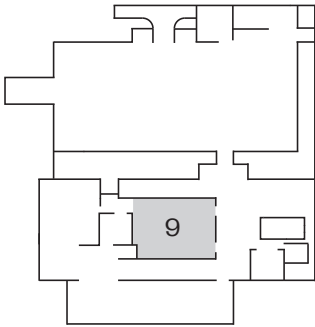

2019–2022
Sound installation
22 min.
Sound engineer:
Andrey Titov–Vrublevsky
Commissioned and produced
by V–A–C Foundation

One of the foundational myths of Russian culture—the legend of the city of Kitezh—dates back to the Tatar–Mongol era. It tells the story of how the besieged city of Kitezh was able, through the prayers of its inhabitants, to bury itself in the waters of Lake Svetloyar, and so escape Khan Batu’s invading forces. Lake Svetloyar, which is located in the Nizhny Novgorod region, remains a destination for pilgrimages to this day: it is believed that standing on its banks, one can still hear the bell tolls of the churches that sunk into its depths many hundreds of years ago.

At the turn of the twentieth century, a time during which eschatological feeling was particularly strong, the legend of Kitezh grew into a national symbol. Rimsky–Korsakov’s opera *The Legend of the Invisible City of Kitezh and the Maiden Fevroniya* (1904) is imbued with premonitions of impending catastrophe, of the collapse of the usual order of things, of the rise of a new and unpredictable reality.

In compositions written in 2019 for V–A–C Foundation’s project *DK Zattere*, Vladimir Rannev deconstructs and rethinks the musical material of Rimsky–Korsakov’s opera through the help of electronic sound processing. The static format of the sound installation is consonant with the stopped time in the sunken city, where, as Rimsky–Korsakov’s birds of paradise sing, “the eternal moment has come.” To Rannev’s mind, the city of Kitezh is above all an acoustic phenomenon: invisible, but clearly audible.

Vladimir Rannev
See page 21

10 Oleg Gudachev Archipelago

Level -1, Pump room

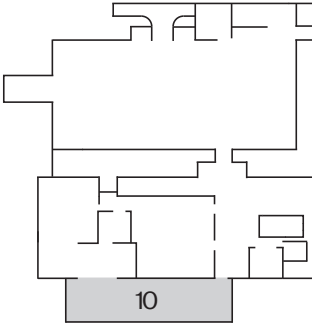

2020–2022
Sound installation
28 min.
Sound engineer:
Andrey Titov–Vrublevsky
Commissioned and produced
by V–A–C Foundation

The invisible islands out of which the Saint Petersburg-based composer, theorist, and improviser Oleg Gudachev has composed his *Archipelago* are soundscapes recorded at different ends of the earth. *Archipelago*'s two main "islands" are an eight-channel audio-recording of the world's largest hydroelectric power station—the Three Gorges Dam in China—and a six-channel recording of the sound of New York City which features a solo for a slowed down police siren.

Archipelago is Gudachev's first venture into the genre of sound installation. Previously, he has composed dramaturgical works that unfold in time and have clearly distinguishable beginnings, middles, and ends. This makes *Archipelago* unusual in as far as it can be listened to from any moment, and as many times as one likes.

For Gudachev, *Tuning* is a natural continuation of many years of experimentation with spatial music—a genre founded on the interaction of sound and concrete spaces. Gudachev features here as both a composer and a multi-instrumentalist, working at the juncture of acoustic and electronic music to produce a piece that is almost symphonic in its complexity and volumes.

Oleg Gudachev

(Leningrad, 1988)

is a composer and improvisational multi-instrumentalist. He graduated with a degree in Composition from the Rimsky-Korsakov Saint Petersburg State Conservatory and is a post-graduate student at the Vaganova Ballet Academy. He is the co-founder and artistic director of the {instead}

ensemble. In 2020, he was resident artist at HELLERAU—European Centre for the Arts and the winner of the Aksenov Family Foundation's Russian Music 2.0 grant. He has written the music for productions at many Russian theatres, including the Alexandrinskiy Theatre and the Tovstonogov Bolshoi Drama Theatre.

11 Dmitry Vlasik GES-2 Opera

Level -1, Parking

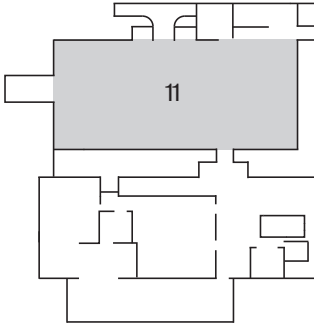

2020–2022

Sound installation

Variable duration

Performers: Yulia Migunova (cello)
and Alexandra Serikova (voice)

Programming: Mikhail Myasoyedov

Commissioned and produced

by V–A–C Foundation

Anton Svetlichny's *Forms
of Tenderness* (see page 26)
plays here 16:00–22:00,
Monday to Sunday

Dmitriy Vlasik's sound installation has a long history.

In 2015, as part of V–A–C Foundation's *GES-2 Data* project, the director Vsevolod Lisovsky recorded conversations with former power station employees. The poet Andrey Rodionov then thought up a means of transforming these conversations into a poetic work, or "poetic verbatim".

This poetic verbatim went on to serve as the basis for the libretto to *GES-2 Opera*. The opera follows the boiler worker, Ilya Vlasov, as he recalls his daily routine, the process of checking equipment, an accident in which a number of plant workers were killed, and explains why he and his colleagues had such difficulty letting go of the past. Dmitry Vlasik's score, written with Alexandra Serikova, centres itself on the complex sound palette produced by the hum of the turbines of the GES-1 power plant on the Raushskaya Embankment, which once formed a joined enterprise with GES-2.

These same turbines served as the foundation for Vlasik's eponymous new sound installation. The hum of the turbines was put through a thorough acoustic analysis and reproduced with the help of classical instruments—cello and voice. In this way, sounds produced as by-products of the generation of electricity—a kind of slag, if you will—have come to form the basis for artistic expression.

GES-2 Opera premiered in 2019, in the constructivist building of the Moscow Energy Institute, where many of GES-2's employees would once have studied. Today, echoes of this production, akin to acoustic spectres, will sound out in the renovated power station's Parking.

Dmitry Vlasik

(Moscow, 1981)

is a composer, performer, and the author of a number of sound performances. He has written music for productions by Dmitry Volkostrelov, Marat Gatsalov, Elena Gremina, Kirill Serebrennikov, and Andrey Stadnikov. He is a soloist at the Moscow Philharmonic Society and a member of the Moscow Contemporary Music Ensemble.

12 Anton Svetlichny Forms of Tenderness

Level -1, Parking

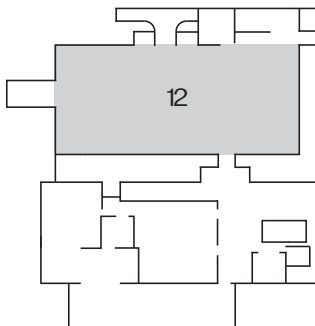

2022
Sound installation
Variable duration

Performers:

Elizaveta Boytsanova *flute*
Anastasiya Kamenskaya *keyboards*
Maria Kovalyova *voice*
Sofia Kushnir *oboe*
Tatiana Lukina *violin*
Omar Saidov *drums*
Ariy Samoylenko *saxophone*
Anton Svetlichny *keyboards*
Anna Serdyukova *guitar*
Alexandra Serikova *voice*
Ivan Sobolev *flute*
Alexander Soldatenko *guitar*
Kirill Tatyanko *guitar*
Filipp Teratsuyan *bass guitar*
Ilya Fokin *electronics*
Alisa Shestunova *keyboards*

Sound engineer:

Andrey Titov– Vroublevsky
Commissioned and produced
by V–A–C Foundation

Dmitry Vlasik's *GES-2 Opera*
(see page 25)
plays here 11:00–16:00,
Monday to Sunday.

As a rule, people tend not to linger in the House of Culture's underground parking lot. The coldness of this space asks to be softened, its emptiness to be filled with comfort, with life (be it a virtual one), with visitors (be they imaginary), to be made more supple and more unpredictable. At present, the parking is predominantly populated by cars, and they turn out to be the primary public of *Forms of Tenderness*. This place where machines are at rest has been turned into a space of mechanical sleep by Anton Svetlichny—an “espace du sommeil,” to borrow the French surrealist poet Robert Desnos's expression.

The installation consists of a series of tracks recorded with the participation of live musicians on acoustic and electronic instruments. Though they are stylistically diverse—jazz, pop, electronic music, minimalism, ambient—each track is alike in working with images of tenderness, softness, lyricism, stasis, and rest. Then, the computer sets in—a real-time algorithm composes an endless and endlessly changing lullaby from the recordings, as it were lulling the void, just as the chorus of nannies in Tchaikovsky's *Iolanta* lulls the opera's blind protagonist.

Anton Svetlichny

(Rostov-on-Don, 1982) is a composer and pianist. He is a graduate of the Rostov State Rachmaninov Conservatory's composing faculty and a winner of the Pythian Games composing competition. He is a member of the “Resistance material” group of composers, and a co-founder of the contemporary music ensemble InEnsemble.

“For me, GES-2 is a utopia of conflictless existence where one always finds a place for creativity, joy, tranquility. The space—permeated with light, full of air—allows for unhindered movement, playful possibilities, a diversity of routes. Things are different in the Parking. When people find themselves here, they are, strictly speaking, already yet to enter the ‘real House of Culture.’ This observation gave rise to one of the tasks of this installation—to draw the Parking into the general mode of feeling at GES-2, to select an audio analogue for it in order to achieve a similar emotional effect.”

Anton Svetlichny

13 Darya Zvezdina (with Andrey Guryanov)

I must go seek some dewdrops here

Level 1, Forest

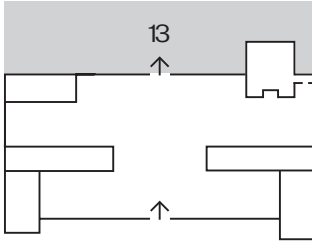

2020–2022

Sound installation

62 min.

Performers: N'Caged

Vocal Ensemble

Director: Arina Zvereva

Commissioned and produced
by V–A–C Foundation

In her installation, *I must go seek some dewdrops here*, Darya Zvezdina works with the rarest timbres of the human voice, which are usually barely audible. Here, they have been made into a piece of music for four soloists, first recorded in studio, then digitally processed.

Such sounds might be made by the spirits of the trees in GES-2's Forest: emphatically impersonal at first, they gradually turn into a voice that hints at the presence of some fragile, humanlike creature. Thanks to multi-channel playback, sound arrays of various volumes and durations move around the Forest. They gather into a dense cloud and then disperse, randomly following on from one another.

Darya Zvezdina calls this vibrant organic structure which changes shape in space and time an “acoustic mycelium.” “I don't think I ever seriously wondered where the boundaries of the concept of ‘music’ may lie,” she notes, “for me, music is everything that sounds. Or literally everything, if needed.” Her 60-minute piece is repeated many times in different versions and projections, transforming the Forest into an endlessly renewing soundscape.

Darya Zvezdina

(Chelyabinsk, 1990)

is a composer and improviser. She studied at the Ural State Mussorgsky Conservatory and the Moscow State Tchaikovsky Conservatory. She has won numerous awards for her compositions, both in Russia and internationally. She was a composer-in-residence at HELLERAU—European Centre for the Arts (2020).

Andrey Guryanov

(Moscow, 1987)

is an artist, sound engineer, and composer. He studied at the Saint Petersburg State University of Film and Television and the Rodchenko Art School in Moscow. He works

with sound installations and with the sound for film, theatre, and performance.

Arina Zvereva

(Moscow, 1978)

is a conductor and singer. She is the founder and leader of the N'Caged Vocal Ensemble and the choirmaster of the Stanislavsky Electrotheatre. She graduated from the Moscow State Tchaikovsky Conservatory. She won a Golden Mask National Theatre Award in 2021.

N'Caged Vocal Ensemble

is a collective specialising in contemporary music. They collaborate closely with Russian

and foreign composers and work with the Stanislavsky Electrotheatre on a permanent basis.

14 Vangelino Currentzis Resonance

Level 1, Prospekt
Level 2, Platform

22 Apr —
14 Jul
2022

2020–2022
Sound installation
20 min.
Performers: musicAeterna
Conductor: Teodor Currentzis
Remastered for GES-2
by Damien Quintard
Commissioned and produced
by V–A–C Foundation

Resonance is a twenty-minute modular piece written by Vangelino Currentzis and performed by the musicAeterna orchestra under the direction of Teodor Currentzis in Dom Radio, Saint Petersburg. The installation was conceived especially for GES-2'S Prospekt and Platform, and a special array was developed for the recording: twenty-four musicians were placed at the same distance from one another as the speakers used to broadcast the composition on GES-2's Prospekt would be.

Resonance was to have taken its final form upon installation at the House of Culture. It was significantly reworked as a consequence of the pandemic. The version of the installation exhibited here was created in anticipation of a meeting between GES-2 and the artist.

Vangelino Currentzis

(Athens, 1973)

is a musician, composer, sound artist,
and producer.

15 Tuning. Concerts

Recordings of the *Tuning* concert programme are available on the V–A–C Foundation YouTube channel



Curator:
Dmitry Renansky

Performers:
Alexei Lubimov
Vladislavs Nastavševs
Dmitry Zubov
Intrada Vocal Ensemble (Ekaterina Antonenko, artistic director and conductor)
Questa Musica Ensemble (Philipp Chizhevsky, conductor)
Moscow Contemporary Music Ensemble
Soloists of the *Pratum Integrum* orchestra

Producers:
Ekaterina Arkhipova, Marina Badudina, Alexandra Chistova, Ksenia Makshantseva, Iana Romashkina

What form can concerts take today? What relation does tradition have to modernity in this format? As it searched for answers to this question, the *Tuning* concert programme ran the gamut of genres and forms, balancing at the boundary that separates old and new, spiritual and secular, between individual and collective feelings and experiences.

The protagonist of Alexei Lubimov's solo performance was an 1848 *Érard* piano from the collection of Alexey Stavitsky. Performing works by Mozart, Beethoven, and Chopin, Lubimov sought to reproduce the conditions in which art of the turn of the nineteenth century would have been perceived in the late Romantic era. Can one compare the perception of classical music in the mid-nineteenth century with how it is perceived today?

The concert might seem a fundamentally secular genre, and the sacred the lot of past art. The musicians of the Intrada Vocal Ensemble and the Questa Musica Ensemble, however, questioned this assertion: their programme traced a line of spiritual searching from the High Renaissance (Palestrina and Monteverdi) to the Baroque (Lotti and Bach) to the Romantic era (Brahms) before concluding in the contemporary with the world premiere of Alexey Sysoev's *Mass*.

In an era of the comingling of genres, the concert stage can seem the last stronghold of "pure music." But is this always the case, and where does the line separating concert from musical theatre and performance lie today? The finale of Joseph Haydn's *Farewell* symphony (1772) has performers leave the stage one after another as it gradually falls into darkness. This first and notable example of instrumental theatre was joined in *Tuning's* playbill by Vladislavs Nastavševs's *Lyrical Scenes*, a work at the junction between solo concert and solo performance.

The final evening of the first *Tuning* concert cycle saw works by the organist and chief composer of Venice's Saint Mark's Cathedral Giovanni Gabrieli (1556–1612) sound out on GES-2's Prospekt alongside works by contemporary Russian composers. The programme proposed a comparison of works of the sixteenth and twenty-first century and in

doing so developed *Tuning's* central theme, the dialogue between music and architecture. Composers, performers, and listeners confronted the new volumes of GES-2 and were the first to experience live sound in the space of the House of Culture. Renzo Piano, the architect who oversaw the reconstruction of GES-2, repeatedly underlined the former power plant's resemblance to a basilica, terming the Prospekt its "nave." The music which Gabrieli composed for the many-levelled Saint Mark's Cathedral thus sounded entirely fitting under the arches of GES-2. The exploration of the dialogue between sound and architecture was continued in works composed by Boris Filanovsky and Anton Svetlichny in 2021 and 2022 especially for the *Tuning* programme.

Time Regained

In June 2022, the *Tuning* project continued its concert programme, bringing epochs and generations, Europe and Russia, leading lights and debutants into dialogue with one another. In 1687, Johann Adam Reincken (1643–1722) released his *Hortus musicus* (Musical garden), a collection of six sonatas and suites for two violins, viola, and *basso continuo*, one of the most important works of the German Baroque corpus. Almost twenty years later, Johann Sebastian Bach (1685–1750) recomposed the first sonata of the *Hortus musicus* for the harpsichord, thus entering into dialogue with his predecessor. As part of *Tuning's* concert programme, Reincken's original compositions were performed by the soloists of the *Pratum Intergrum* orchestra, while Bach's reworked *Hortus musicus* was performed by the Russian harpsichordist Dmitry Zubov. Zubov's solo programme saw compositions from different periods of Bach's work provide a breathtaking panorama of his oeuvre: from the early Capriccio BWV 993 to the late Duet BWV 804.

One of *Tuning's* central themes was authentic performance, which in professional circles is often termed "historically informed" performance. This idea is key to our contemporary conception of interpretative art, which is understood first and foremost as a cultural task. Following this approach, the performer attempts to reproduce the sound of music of the past in strict accordance with the spirit of the era through the use of historical instruments. The performer seeks to present old masters as relevant, contemporary artists, thus going against a linear view of the development of art and turning away from the idea

of artistic completeness. It is no coincidence that the *Pratum Integrum* Orchestra's concert closed with Vladimir Martynov's *Passionslieder* (*Passion songs*, 1977), a score that is both a landmark of the late Soviet musical avant-garde and genetically related to European baroque music.

Movement through history was the central theme of the *Made in GES-2* concert, performed by the Moscow Contemporary Music Ensemble. Four new works, commissioned by the V-A-C Foundation especially for *Tuning*, reflected on the nature of the post-Soviet music scene. World premieres of works by Mark Buloshnikov (Nizhny Novgorod), Valery Voronov (Belarus/Germany), Yuri Krasavin (Saint Petersburg) and Dariya Maminova (Cologne/Saint Petersburg) cast this period as a polyphony which brought together seemingly opposed artistic approaches and points of view.

Exhibition
plans

2

Level 1

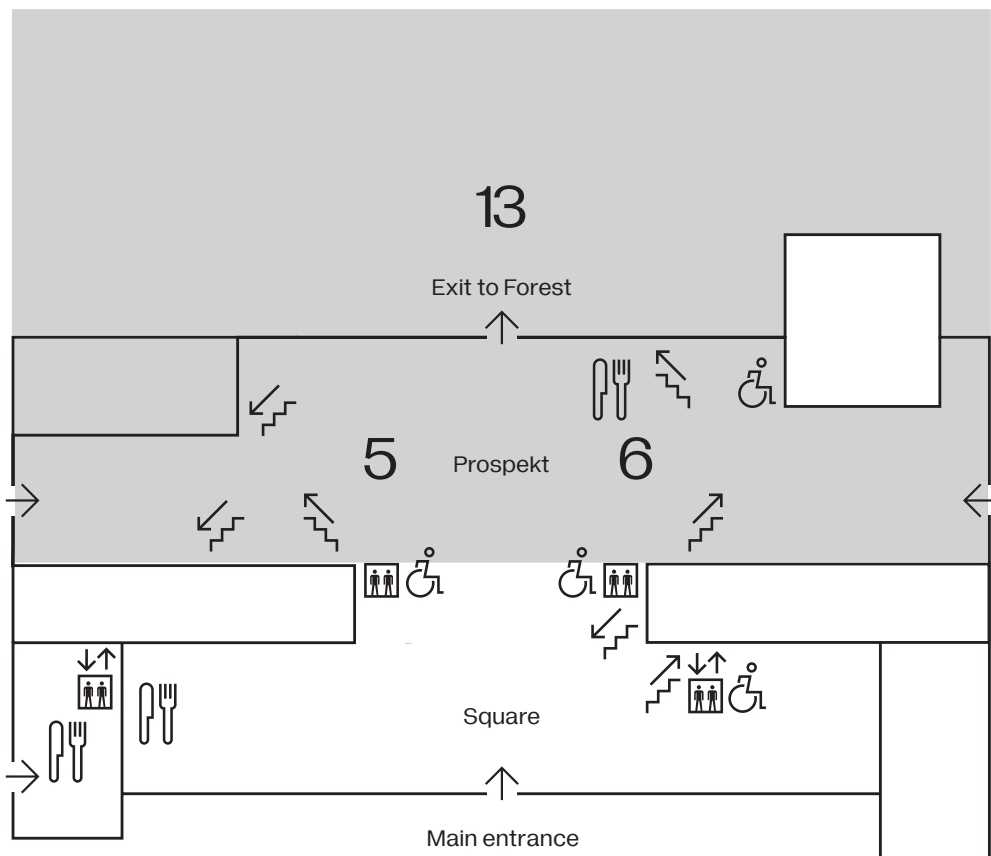

5.
Mark Buloshnikov
Moments
(until 17:00)

6.
Ivan Bushuev
I campi dei ricordi
(*Fields of memories*)
(after 17:00)

13.
Darya Zvezdina
(feat. Andrey Guryanov)
*I must go seek some
dewdrops here*

Level 2

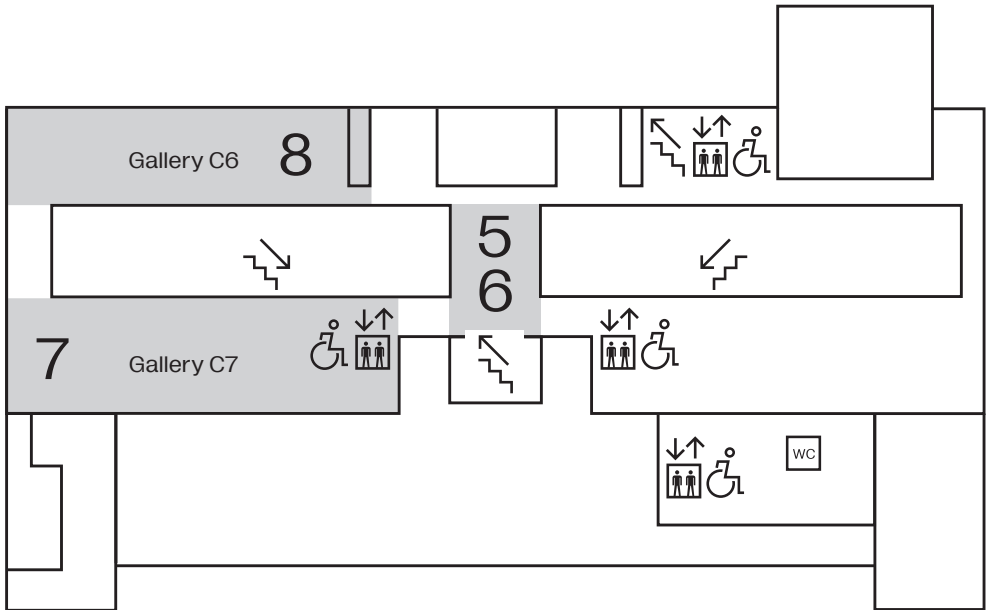

5.
Mark Buloshnikov
Moments
(until 17:00)

6.
Ivan Bushuev
I campi dei ricordi
(Fields of memories)
(after 17:00)

7.
Vladimir Rannev
Tuning

8.
Eduard Artyemyev
GES-2. Anthology. Part I.

Level -1

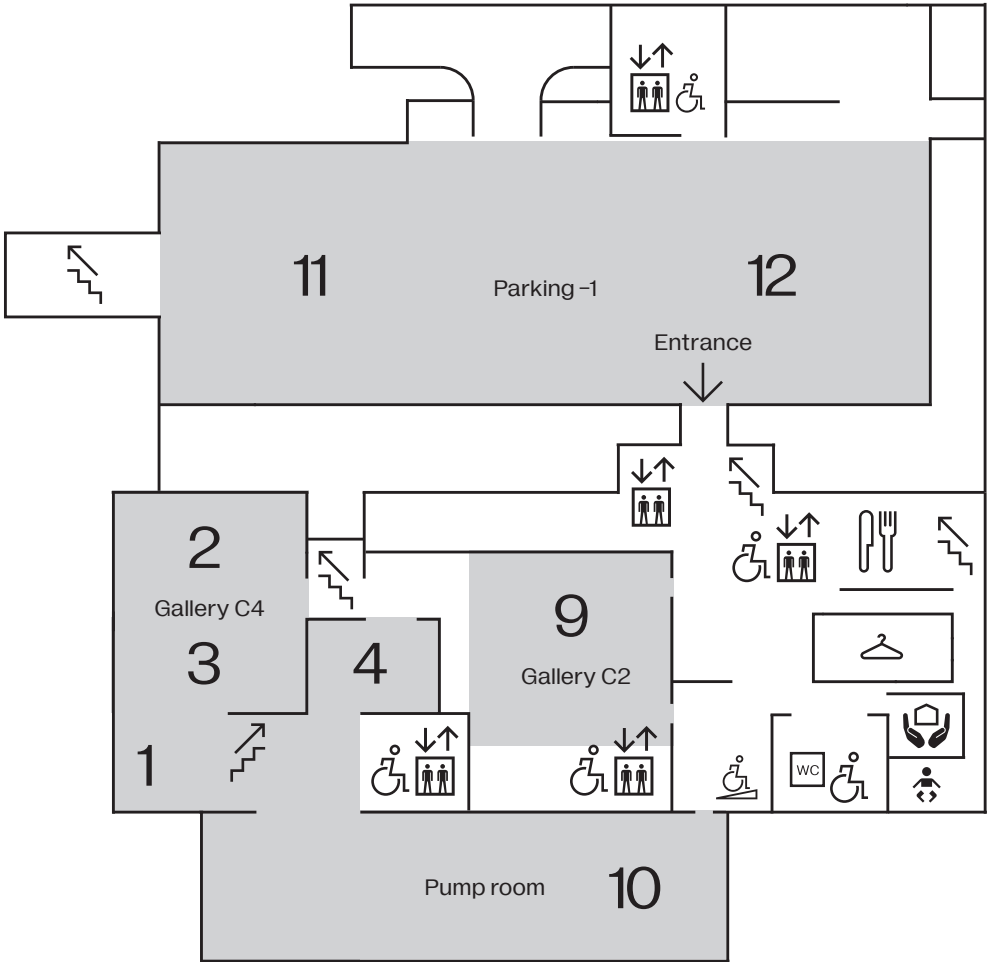

Level -1

1.
Non-objectivity
as a new visual language

2.
Three-dimensional
experiments

3.
On the threshold
of the visible

4.
Practicing the
collective gesture

9.
Vladimir Rannev
Kitezh

10.
Oleg Gudachev
Archipelago

11.
Dmitry Vlasik
GES-2 Opera
(until 16:00)

12.
Anton Svetlichny
Forms of Tenderness
(after 16:00)

Curators:

Andrei Vasilenko, Andrey Parshikov,
Dmitry Renansky, Karen Sarkisov,
Elena Yaichnikova

Authors:

Victor Alimpiev, Paweł Althamer,
Eduard Artemyev, Tauba Auerbach,
Alighiero Boetti, Louise Bourgeois,
Constantin Brâncuși, Mark Buloshnikov,
David Burliuk, Ivan Bushuev, Sarah
Charlesworth, Vangelino Currentzis,
Enrico David, Liz Deschenes, Alexandra
Exter, Boris Filanovsky, Günther
Förg, Piotr Galadzhiev, Isa Genzken,
Alberto Giacometti, Vladimir Gorlinsky,
Oleg Gudachev, Wade Guyton, Hans
Hartung, Dariya Maminova, Henry
Moore, Sara Morris, Wassily Kandinsky,
Daniel Knorr, Willem de Kooning, Yuri
Krasavin, Giuseppe Penone, Sigmar
Polke, Florian Pumhösl, Vladimir Rannev,
Gerhard Richter, Bridget Riley, Anton
Svetlichny, Alexey Sysoev, Cheyney
Thompson, Rosemarie Trockel, Victor
Vasarely, Dmitry Vlasik, Valery Voronov,
Darya Zvezdina (featuring Andrey
Guryanov)

Performers:

Ekaterina Antonenko, Mary
Cheminava, Philipp Chizhevsky, Teodor
Currentzis, Alexei Lubimov, Yulia
Migunova, Vladislavs Nastavševs,
Aleksandra Serikova, Arina Zvereva,
Dmitry Zubov, Intrada Vocal Ensemble,
Moscow Contemporary Music
Ensemble, musicAeterna Orchestra,
N'Caged Vocal Ensemble, Pratum
Integrum Orchestra, Questa Musica
Ensemble

Custodians:

Daria Krivtsova, Sofiya Lazareva

Producers:

Stasy Dementyeva, Alisa Kekelidze,
Ksenia Lukina, Ksenia Makshantseva,
Iana Romashkina

Graphic design:

Kirill Gorbunov, Vasily Kondrashov

Technical production:

Andrey Belov, Alexandr Dolmatov,
Artem Kanifatov, Konstantin Petruk,
Ivan Samokhin, Nikita Tolkachev

Editors:

Daniil Dugaev, Olga Grinkrug

English texts:

Charlotte Neve

GES-2 House of Culture brings together exhibition halls, a library, a cinema and concert hall, artist workshops, studios, and residencies, shops, a restaurant, cafes, a playground, and an auditorium for public educational events. The purpose of the House of Culture is to acquaint a wide audience with contemporary culture and encourage visitors to actively take part in its shaping.

GES-2 is the main site of the V–A–C Foundation in Russia. The Foundation works with Russian artists to expand the cultural space by holding exhibitions, publishing books, and running educational initiatives.

Information partners:

t.me/culturepeople

АРТГИД

BURO.

ИСКУССТВО
ДЛЯ ПАЦАНЧКОВ



t.me/fermate

